



**HEIDENHAIN**



Product Information

## **RCN 200**

Absolute Angle Encoders  
with Integral Bearing

# RCN 200

- Integrated stator coupling
- Hollow through shaft  $\varnothing 20$  mm
- System accuracy:  $\pm 6''$  and  $\pm 8''$
- Fault exclusion for loosening of the mechanical connection is possible

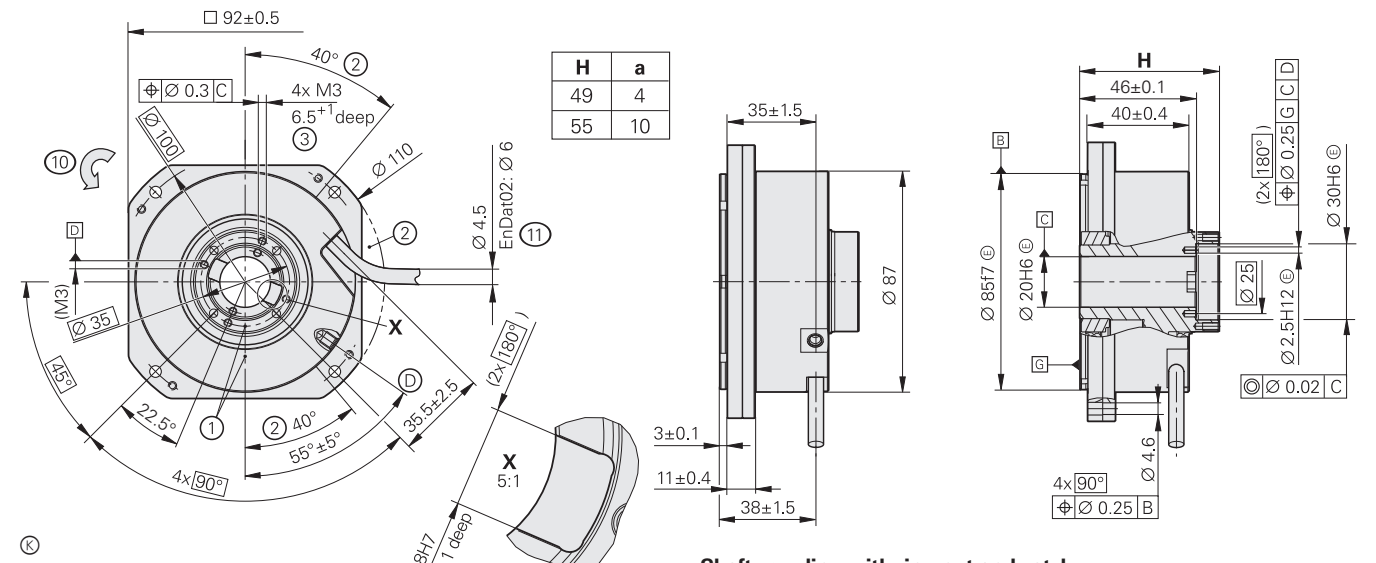

Ⓢ Shaft coupling with ring nut  
Without mechanical fault exclusion

Ⓢ Shaft coupling with ring nut and catch  
With mechanical fault exclusion  
(for other dimensions, see without fault exclusion)

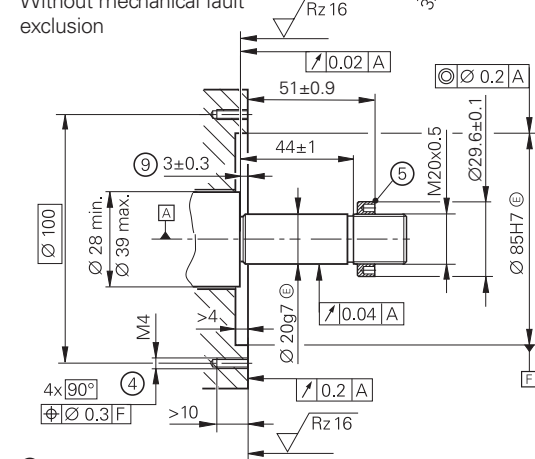

Ⓢ Front-face shaft coupling  
Without mechanical fault exclusion

Ⓢ Front-end shaft coupling  
With mechanical fault exclusion  
(for other dimensions, see without mechanical fault exclusion)

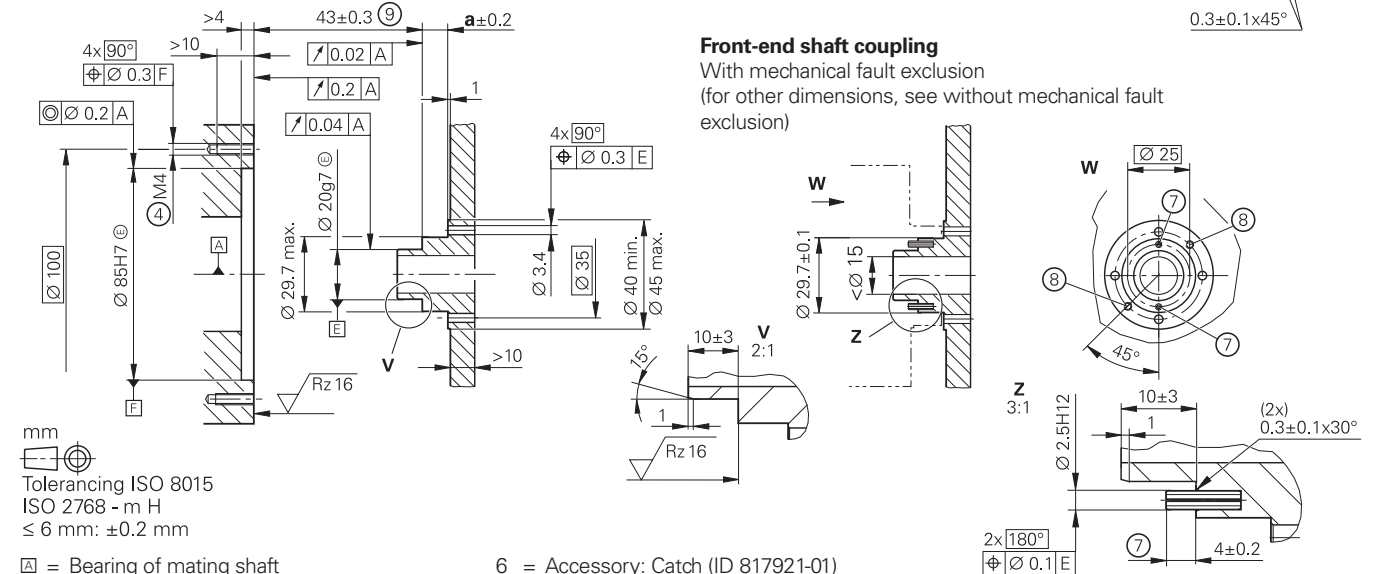

mm  
Tolerancing ISO 8015  
ISO 2768 - m H  
≤ 6 mm: ±0.2 mm

- Ⓢ = Bearing of mating shaft
- Ⓢ = Compressed air inlet
- Ⓢ = Required mating dimensions
- 1 = Mark for 0° position  $\pm 5^\circ$
- 2 = Free space for customer
- 3 = Thread engagement: 4.5 mm  $\pm 0.5$  mm
- 4 = Thread engagement: > 7.5 mm
- 5 = Accessory: ring nut (ID 336669-03)

- 6 = Accessory: Catch (ID 817921-01)
- 7 = Two spring pins ISO 8752-2.5 x 10-St
- 8 = Provide additional back-off thread (M3) when spring pins are used (otherwise optional)
- 9 = Tolerance specification includes mounting tolerances and thermal expansion; no dynamic movement permitted
- 10 = Direction of shaft rotation for ascending position values
- 11 = Cable support max. 50 mm

	RCN 210	RCN 280	RCN 290F	RCN 290M
<b>Measuring standard</b>	DIADUR circular scale with absolute track and incremental track (2048 lines)			
<b>System accuracy*</b>	$\pm 6''$ ; $\pm 8''$			
Position error per signal period	$\leq \pm 1.5''$			
<b>Interface</b>	EnDat 2.2		Fanuc Serial Interface $\alpha$ Interface	Mitsubishi High Speed Interface
Ordering designation*	EnDat22	EnDat02	Fanuc05	Mit03-4
Position values per revolution	33554432 (25 bits); <i>Fanuc <math>\alpha</math> Interface</i> : 8388608 (23 bits)			
Electrically permissible speed	$\leq 3000$ rpm for continuous position values			
Clock frequency	$\leq 16$ MHz	$\leq 2$ MHz		
Calculation time $t_{cal}$	$\leq 6$ $\mu$ s	$\leq 9$ $\mu$ s		
Incremental signals		$\sim 1 V_{PP}$		
Cutoff frequency -3 dB		$\geq 400$ kHz		
<b>Electrical connection</b>	Cable (1 m) with 8-pin M12 coupling (male)	Cable (1 m) with 17-pin M23 coupling (male)	Cable (1 m) with 8-pin M12 coupling (male)	
Cable length <sup>1)</sup>	$\leq 150$ m		$\leq 50$ m	$\leq 30$ m
Supply voltage	DC 3.6 V to 14 V			
Power consumption <sup>2)</sup> (max.)	3.6 V: $\leq 0.72$ W; 14 V: $\leq 0.8$ W			
Current consumption (typical)	5 V: 100 mA (without load)			
<b>Shaft*</b>	Hollow through shaft, D = 20 mm, with lengths of 49 mm or 55 mm			
Mech. permissible speed	$\leq 3000$ rpm			
Starting torque at 20 °C	Typically $\leq 0.16$ Nm			
Moment of inertia	Height H = 49 mm: rotor (hollow shaft): $91 \cdot 10^{-6}$ kgm <sup>2</sup> ; stator (housing/flange): $570 \cdot 10^{-6}$ kgm <sup>2</sup> Height H = 55 mm: rotor (hollow shaft): $97 \cdot 10^{-6}$ kgm <sup>2</sup> ; stator (housing/flange): $570 \cdot 10^{-6}$ kgm <sup>2</sup>			
Permissible axial motion of measured shaft	$\pm 0.3$ mm			
<b>Natural frequency</b>	$\geq 1000$ Hz			
<b>Vibration</b> 55 Hz to 2000 Hz	$\leq 200$ m/s <sup>2</sup> (EN 60068-2-6)			
<b>Shock:</b> 6 ms	$\leq 200$ m/s <sup>2</sup> (EN 60068-2-27)			
<b>Operating temperature</b>	0 °C to 60 °C -20 °C to 60 °C <sup>3)</sup>			
<b>Protection</b> EN 60529	IP64			
<b>Mass</b>	$\approx 0.8$ kg			

\* Please select when ordering

<sup>1)</sup> With HEIDENHAIN cable:  $\leq 8$  MHz

<sup>2)</sup> See *General electrical information* in the *Interfaces of HEIDENHAIN Encoders* brochure

<sup>3)</sup> No fault exclusion for the loosening of the mechanical connection

# Calibration chart

HEIDENHAIN prepares individual calibration charts (**Quality Inspection Certificates**) for the RCN 2xx encoders and ships them with the unit. The Quality Inspection Certificate confirms that the encoder meets the specified system accuracy. It is ascertained through five forward and five backward measurements. The measuring positions per revolution are selected such that both the long-range error and the position error within a single signal period are ascertained with great accuracy. The reversal error is ascertained with forward and backward measurements at ten positions. The following limit applies to the mechanical hysteresis:  
**RCN 2xx:  $\leq 2''$**

### RCN 2xx with system accuracy $\pm 6''$

The Quality Inspection Certificate contains a measured curve showing the mean values of the position errors from five forward and backward measurements without hysteresis. The maximum position errors of the measured curve within  $360^\circ$  and within one signal period are indicated separately. Furthermore, the arithmetic mean and the maximum value of the hysteresis are documented.

### RCN 2xx with system accuracy $\pm 8''$

The Quality Inspection Certificate does not include information on the measured values.

# Mounting

## General information

### Mounting

The housing of the RCN 2xx is firmly connected by an integral mounting flange and a centering collar to the stationary machine part.

### Shaft coupling with ring nut (ID 336669-03)

For installation, the hollow through shaft of the angle encoder is placed over the machine shaft, and is fixed with a ring nut from the front of the encoder. The ring nut can be easily tightened with the mounting aid (ID 530334-03).

### Front-end shaft coupling

The hollow shaft is attached with the threaded holes on the face using special mounting elements fitted to the individual design (not included in delivery).

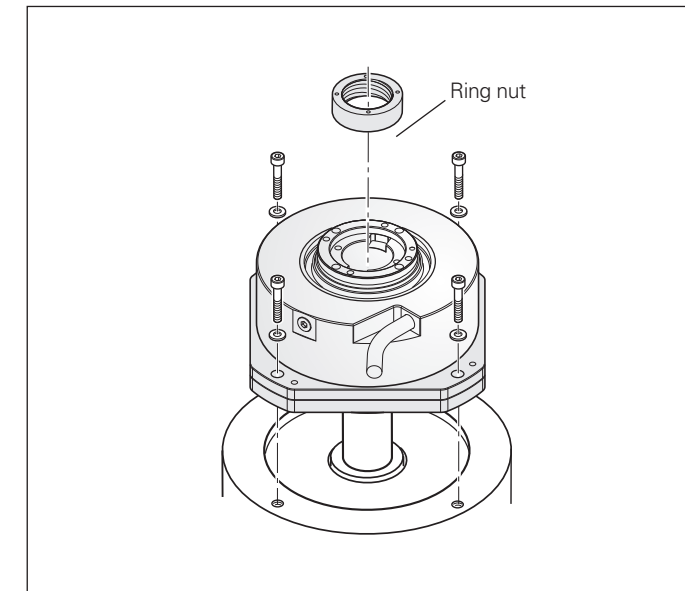

Shaft coupling with ring nut

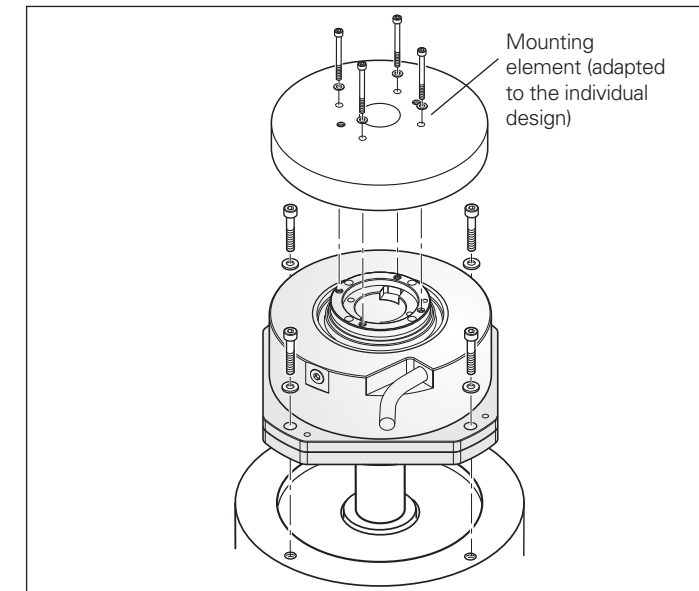

Front-end shaft coupling

**Permissible angular acceleration:**  
 (without fault exclusion for the loosening of the mechanical connection)  
**RCN 2xx:  $1000 \text{ rad/s}^2$**

### Material

The materials stated in this table must be used for the machine shaft and fastening components.

	Mating shaft	Mating stator
<b>Material</b>	Ferrous materials (steel/cast iron materials)	
<b>Tensile strength <math>R_m</math></b>	$\geq 600 \text{ N/mm}^2$	$\geq 250 \text{ N/mm}^2$
<b>Shear strength <math>\tau_B</math></b>	$\geq 390 \text{ N/mm}^2$	$\geq 290 \text{ N/mm}^2$
<b>Interface pressure <math>p_G</math></b>	$\geq 660 \text{ N/mm}^2$	$\geq 275 \text{ N/mm}^2$
<b>Modulus of elasticity <math>E</math></b>	$110\,000 \text{ N/mm}^2$ to $215\,000 \text{ N/mm}^2$	
<b>Coefficient of expansion <math>\alpha_{\text{them}}</math> (at <math>20^\circ\text{C}</math>)</b>	$10 \cdot 10^{-6} \text{K}^{-1}$ to $17 \cdot 10^{-6} \text{K}^{-1}$	
<b>Mounting temperature</b>	All information regarding screw connections is based on a mounting temperature of $15^\circ\text{C}$ to $35^\circ\text{C}$	

# Mounting

## Mechanical fault exclusion

### Fault exclusion for the loosening of the mechanical connection

There are possibilities for attaching the RCN 2xx that rule out such errors.

Whereas the housing or flange is standardly mounted with fastening screws, special factors must be taken into consideration for the hollow-shaft connection. When coupling the shaft with a ring nut, a **catch** (ID 817921-01) must be used (moment of inertia of ring nut and catch:  $4.8 \cdot 10^{-6} \text{ kgm}^2$ ).

Alternatively, this type of fault exclusion is also possible for front-end shaft coupling with mounting screws and spring pins. For more information on this topic and on limitations to the specifications, please refer to the table below.

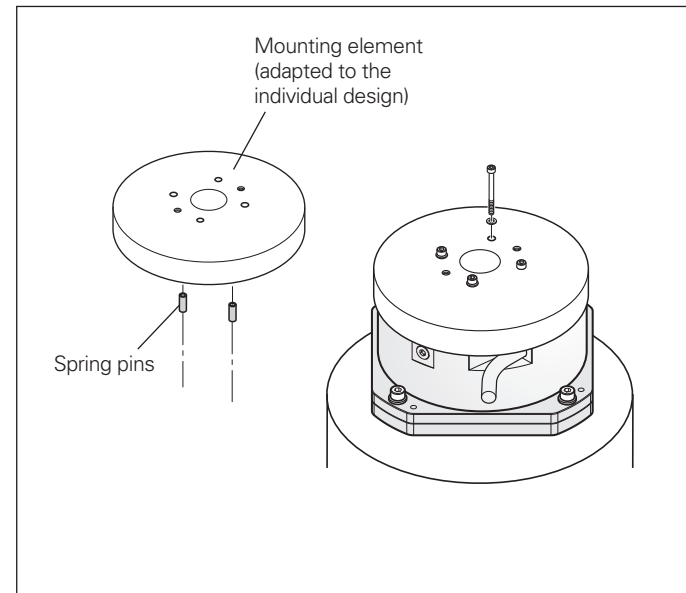
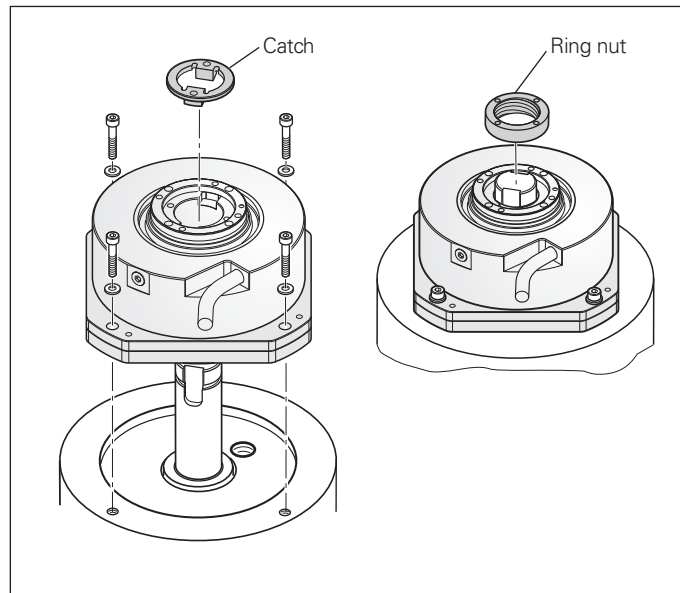

Mechanical connection	Fastening <sup>1)</sup>	Safe position for the mechanical connection <sup>2)</sup>	Limited specifications <sup>3)</sup>
<b>Housing/flange</b>	Screws: M4 ISO 4762 8.8	$\pm 0^\circ$	See Specifications: • Operating temperature See <i>Mounting</i> : • Permissible angular acceleration
<b>Hollow shaft</b> Shaft coupling with ring nut	Ring nut and catch (see <i>Mounting</i> )	$\pm 0.55^\circ$	
<b>Hollow shaft</b> Front-face shaft coupling	Screws: M3 ISO 4762 8.8 Spring pins: ISO 8752 – 2.5 x 10 – St	$\pm 0.07^\circ$	

<sup>1)</sup> A suitable anti-rotation lock must be used for the screw connections (mounting/servicing)  
<sup>2)</sup> Fault exclusion is granted only for the explicitly mentioned mounting options  
<sup>3)</sup> Compared with shaft coupling without mechanical fault exclusion

Fault exclusion is thereby possible for the loosening of the mechanical connection between the encoder and the machine shaft or customer fastening components. For designing the mechanical fault exclusion for other purely customer-side connections, the following encoder torque must be taken into account:

$$M_{Max} = J \cdot \alpha + 4.5 \text{ Nm}$$

$\alpha$ : Max. angular acceleration in the application

J: Moment of inertia of the encoder (rotor or stator; see the specifications) and of the mechanical connection (e.g., ring nut and catch when acceleration is applied through the hollow shaft and shaft coupling via the given components)

### Permissible angular acceleration

Based on where acceleration is applied and on the mounting type, the following values apply to the angular acceleration:

- Permissible angular acceleration of the rotor when acceleration is applied via the hollow shaft and shaft coupling with catch and ring nut:  $20000 \text{ rad/s}^2$

- Permissible angular acceleration of the rotor when acceleration is applied through the hollow shaft and a front-face shaft coupling with fastening screws and spring pins:  $5500 \text{ rad/s}^2$
- Permissible angular acceleration of the stator when acceleration is applied via the flange/housing:  $4000 \text{ rad/s}^2$

# Electrical connection

## EnDat pin layout without incremental signals

8-pin M12 coupling								
	Power supply				Serial data transmission			
	8	2	5	1	3	4	7	6
	$U_P$	Sensor $U_P$	0V	Sensor 0V	DATA	$\overline{\text{DATA}}$	CLOCK	CLOCK
	Brown/Green	Blue	White/Green	White	Gray	Pink	Violet	Yellow

Cable shield connected to housing;  $U_P$  = Power supply voltage

Sensor: The sense line is connected in the encoder with the corresponding power line. Vacant pins or wires must not be used!

## EnDat pin layout with incremental signals

17-pin M23 coupling													
	Power supply					Incremental signals <sup>1)</sup>				Serial data transfer			
	7	1	10	4	11	15	16	12	13	14	17	8	9
	$U_P$	Sensor $U_P$	0V	Sensor 0V	Internal shield	A+	A-	B+	B-	DATA	$\overline{\text{DATA}}$	CLOCK	CLOCK
	Brown/Green	Blue	White/Green	White	/	Green/Black	Yellow/Black	Blue/Black	Red/Black	Gray	Pink	Violet	Yellow



Cable shield connected to housing;  $U_P$  = Power supply voltage

Sensor: The sense line is connected in the encoder with the corresponding power line. Vacant pins or wires must not be used!

<sup>1)</sup> Only with the EnDat01 and EnDat02 ordering designations

# Adapter cables and connecting cables

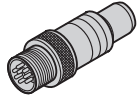
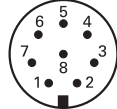
## Fanuc pin layout





8-pin M12 coupling									
									
	Power supply				Serial data transmission				
	8	2	5	1	-	3	4	7	6
	$U_P$	Sensor $U_P$	0V	Sensor 0V	Shield	Serial DATA	Serial DATA	Request	Request
	Brown/Green	Blue	White/Green	White	-	Gray	Pink	Violet	Yellow

**Cable shield** connected to housing;  $U_P$  = Power supply voltage

**Sensor:** The sense line is connected in the encoder with the corresponding power line.

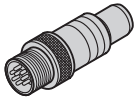
Vacant pins or wires must not be used!

## Mitsubishi pin layout



8-pin M12 coupling									
									
	Power supply				Serial data transmission				
	8	2	5	1	3	4	7	6	
	$U_P$	Sensor $U_P$	0V	Sensor 0V	Serial DATA	Serial DATA	Request Frame	Request Frame	
	Brown/Green	Blue	White/Green	White	Gray	Pink	Violet	Yellow	

**Cable shield** connected to housing;  $U_P$  = Power supply voltage



**Sensor:** The sense line is connected in the encoder with the corresponding power line.

Vacant pins or wires must not be used!

## EnDat adapter cables and connecting cable without incremental signals

PUR connecting cable			$\varnothing 6 \text{ mm}; 2 \times (2 \times 0.09 \text{ mm}^2) + 2 \times (2 \times 0.16 \text{ mm}^2)$	$A_P = 2 \times 0.16 \text{ mm}^2$
<b>Adapter cable</b> with 8-pin M12 connector (female) and 15-pin D-sub connector (female)				1036521-xx
<b>Adapter cable</b> with 8-pin M12 connector (female) and 15-pin D-sub connector (male)				1036526-xx
<b>Connecting cable</b> with 8-pin M12 connector (female) and 8-pin M12 coupling (male)				1036372-xx

## EnDat adapter cables and connecting cable with incremental signals

PUR connecting cable			$\varnothing 8 \text{ mm}; 4 \times (2 \times 0.16 \text{ mm}^2) + 4 \times 0.5 \text{ mm}^2 + 4 \times 0.16 \text{ mm}^2$	$A_P = 2 \times 0.5 \text{ mm}^2$
<b>Adapter cable</b> with 17-pin M23 connector (female) and 15-pin D-sub connector (female)				332115-xx
<b>Adapter cable</b> with 17-pin M23 connector (female) and 15-pin D-sub connector (male)				324544-xx
<b>Connecting cable</b> with 17-pin M23 connector (female) and stripped cable end				309778-xx

## Fanuc/Mitsubishi connecting cable

PUR adapter cable			$\varnothing 6 \text{ mm}; 2 \times (2 \times 0.09 \text{ mm}^2) + 2 \times (2 \times 0.16 \text{ mm}^2)$	$A_P = 2 \times 0.16 \text{ mm}^2$
<b>Connecting cable</b> with 8-pin M12 connector (female) and 8-pin M12 coupling (male)				1036372-xx

$A_P$ : Cross section of power supply lines

$\varnothing$ : Cable diameter (for bending radii, see the *Interfaces of HEIDENHAIN Encoders* brochure)

For more cables, see the *Cables and Connectors* brochure

# HEIDENHAIN

**DR. JOHANNES HEIDENHAIN GmbH**

Dr.-Johannes-Heidenhain-Straße 5

83301 Traunreut, Germany

+49 8669 31-0

+49 8669 32-5061

info@heidenhain.de

[www.heidenhain.com](http://www.heidenhain.com)

This Product Information document supersedes all previous editions, which thereby become invalid. The basis for ordering from HEIDENHAIN is always the Product Information document edition valid when the order is placed.

### More information:

Comply with the requirements described in the following documents to ensure correct and intended operation:

- Brochure: *Angle Encoders with Integral Bearing* 591109-xx
- Mounting Instructions: *RCN 200* 1189093-xx
- Brochure: *Interfaces of HEIDENHAIN Encoders* 1078628-xx
- Brochure: *Cables and Connectors* 1206103-xx

For brochures and Product Information documents, visit [www.heidenhain.com](http://www.heidenhain.com).